



# Standard Test Method for Relative Efficacy of Dynamic Solvent Systems for Dissolving Water-Formed Deposits<sup>1</sup>

This standard is issued under the fixed designation D5256; the number immediately following the designation indicates the year of original adoption or, in the case of revision, the year of last revision. A number in parentheses indicates the year of last reapproval. A superscript epsilon ( $\epsilon$ ) indicates an editorial change since the last revision or reapproval.

## 1. Scope

1.1 This test method covers the determination of the relative efficacy of dynamic solvent systems for dissolving water-formed deposits that have been removed from the underlying material or deposits attached to the underlying material.

1.2 The nature of this test method is such that statements of precision and bias as determined by round robin tests could mislead users of this test method (see Sections 11 and 12). Therefore, no precision and bias statements are made.

1.3 The values stated in SI units are to be regarded as standard. The values given in parentheses are mathematical conversions to inch-pound units that are provided for information only and are not considered standard.

1.4 *This standard does not purport to address all of the safety concerns, if any, associated with its use. It is the responsibility of the user of this standard to establish appropriate safety and health practices and determine the applicability of regulatory limitations prior to use.*

## 2. Referenced Documents

2.1 *ASTM Standards:*<sup>2</sup>

[D887 Practices for Sampling Water-Formed Deposits](#)

[D1129 Terminology Relating to Water](#)

[D1193 Specification for Reagent Water](#)

[D2331 Practices for Preparation and Preliminary Testing of Water-Formed Deposits](#)

[D2777 Practice for Determination of Precision and Bias of Applicable Test Methods of Committee D19 on Water](#)

[D3263 Test Methods for Corrosivity of Solvent Systems for](#)

[Removing Water-Formed Deposits \(Withdrawn 2008\)](#)<sup>3</sup>  
[D3483 Test Methods for Accumulated Deposition in a Steam Generator Tube](#)

## 3. Terminology

3.1 *Definitions:*

3.1.1 For definitions of other terms used in this test method, refer to Terminology [D1129](#).

3.2 *Definitions of Terms Specific to This Standard:*

3.2.1 *dynamic solvent system, n*—any closed loop system in which the solvent is in motion across the deposit surface.

3.2.2 *single and multiple solvent systems, n*—a single solvent system is a one-solution treatment. A multiple solvent system is a treatment using two or more solutions in sequence.

3.2.3 *solvent system, n*—specified chemicals or combination of chemicals, that may include corrosion inhibitors, formulated to react with and remove deposits.

3.2.4 *water-formed deposits, n*—any accumulation of insoluble material derived from water or formed by the reaction of water upon the surface in contact with the water.

3.2.4.1 *Discussion*—Deposits formed from or by water in all its phases may be further classified as scale, sludge, corrosion products, or biological deposits. The overall composition of a deposit or some part of a deposit may be determined by chemical or spectrographic analysis; the constituents actually present as chemical substances may be identified by microscope or x-ray diffraction studies. Organisms may be identified by microscopical or biological methods.

## 4. Summary of Test Method

4.1 This test method consists of determining the ability of a dynamic solvent system to dissolve deposits.

4.2 For the unattached deposits, this test method consists of exposing weighed amounts of deposit to the dynamic solvent systems and determining the weight loss of the exposed deposit, thereby determining the efficacy of the solvent system.

4.3 For the attached deposits, the amount and time required to yield a constant amount of certain loss of interest and the

<sup>1</sup> This test method is under the jurisdiction of ASTM Committee D19 on Water and is the direct responsibility of Subcommittee D19.03 on Sampling Water and Water-Formed Deposits, Analysis of Water for Power Generation and Process Use, On-Line Water Analysis, and Surveillance of Water.

Current edition approved March 15, 2014. Published April 2014. Originally approved 1992. Last previous edition approved in 2009 as D5256 – 05 (2009). DOI: 10.1520/D5256-14.

<sup>2</sup> For referenced ASTM standards, visit the ASTM website, [www.astm.org](http://www.astm.org), or contact ASTM Customer Service at [service@astm.org](mailto:service@astm.org). For *Annual Book of ASTM Standards* volume information, refer to the standard's Document Summary page on the ASTM website.

<sup>3</sup> The last approved version of this historical standard is referenced on [www.astm.org](http://www.astm.org).

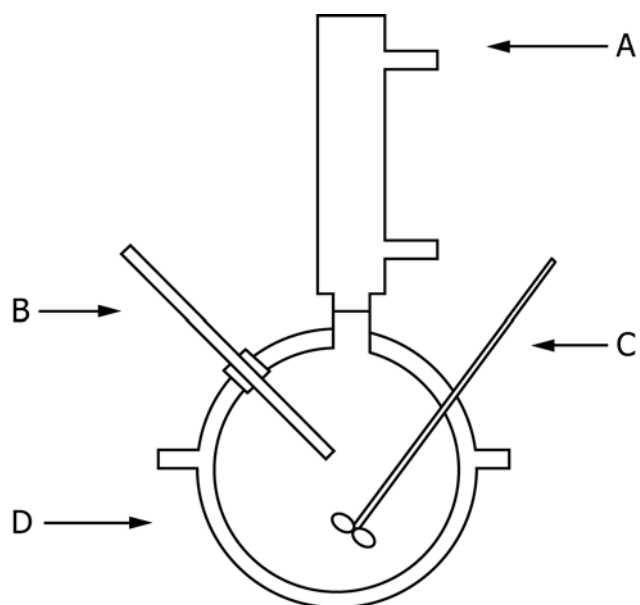

A: Condenser, B: Temperature Measurement, C: Stirrer, D: Heated Reaction Flask

FIG. 1 Low Temperature Test Equipment

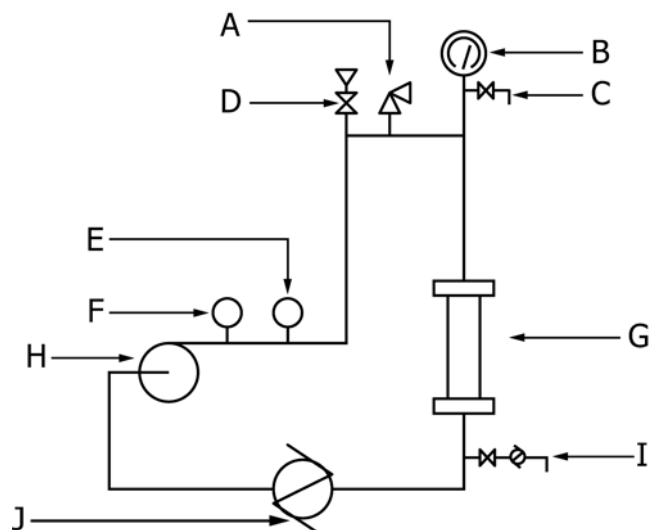

A: High Point Pressure Relief, B: Pressure Gauge, C: Vent, D: Solvent Addition Valve, E: Temperature Measurement, F: Flow Measurement, G: Tube Sample Holder, H: Variable Speed Pump, I: Sample Valve With Integral Cooler, J: Regulated Heat Source

FIG. 3 Dynamic Test Equipment

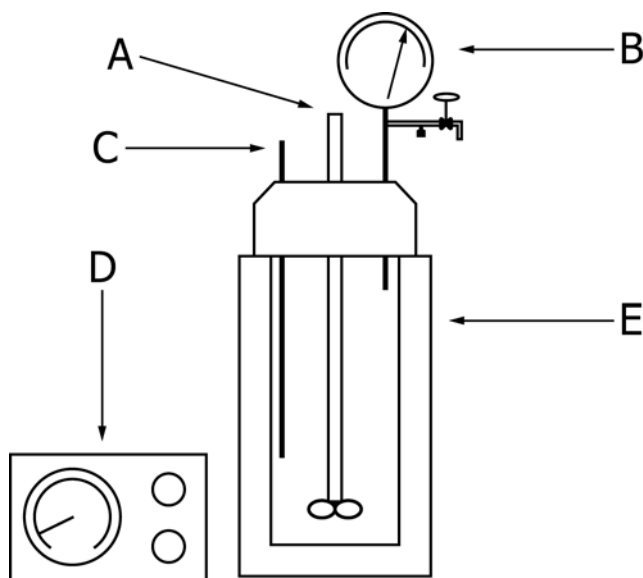

A: Stirrer, B: Pressure Control (Gauge, Vent and Relief), C: Temperature Measurement, D: Temperature Control, E: Heated Autoclave

FIG. 2 High Temperature Test Equipment

amount of deposit not removed determines the relative efficacy of the dynamic solvent system.

## 5. Significance and Use

5.1 This test method is useful because the choice of a solvent system for removing water-formed deposits depends upon the ability of the dynamic solvent system to dissolve both unattached and attached deposits.

## 6. Apparatus

### 6.1 Common Equipment:

NOTE 1—The equipment listed in this section is basic and serves the function of this test method. This basic test procedure could be modified to meet the specific needs of a particular investigation. The test apparatus, however, must be identified and reported with the results. For comparative type tests, as described in the procedure, it is important that all tests be run in an identical manner.

### 6.2 Unattached Deposit Removal (see Fig. 1 and Fig. 2):

- 6.2.1 Balance, capable of weighing to the nearest 0.1 mg.
- 6.2.2 Heating Bath, thermostatically controlled to  $\pm 1^\circ\text{C}$ .
- 6.2.3 Stirrer, controlled agitation.
- 6.2.4 Temperature Indicator.

6.2.5 Reaction Flask, stirred tests are best accomplished in round bottom flasks.

### 6.2.6 Condenser.

6.2.7 Glass Filter Crucibles, Gooch 30-mL low form coarse fritted disc crucibles.

6.2.8 Vacuum Oven, for drying residual deposits.

6.2.9 Desiccator.

### 6.3 Attached Deposit Removal (see Fig. 3):

- 6.3.1 Solvent Heater/Solvent Reservoir.
- 6.3.2 Sample Holder.
- 6.3.3 Flow Controller.
- 6.3.4 Sample System (usually with cooler).
- 6.3.5 Pressure Relief.
- 6.3.6 Pump.
- 6.3.7 Flow Meter.
- 6.3.8 Temperature Controller.

## 7. Reagents

7.1 Purity of Reagents—All solvent materials such as acids, inhibitors, and other additives shall be of the grade normally employed in chemical cleaning practices for the removal of